

JVC

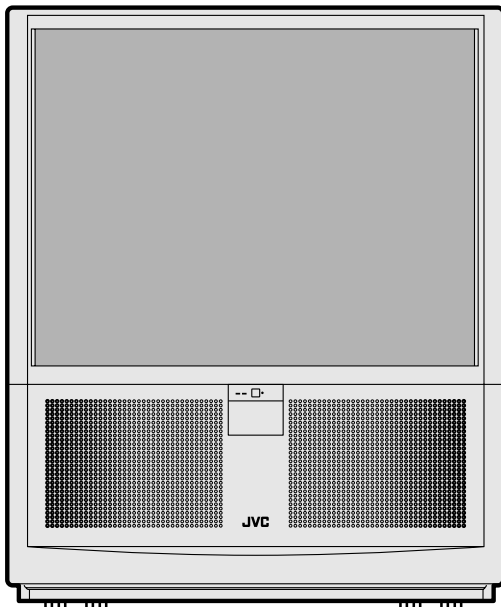

REAR PROJECTION TELEVISION

HV-53PRO



InteriArt
Premiere

DigiPure

100Hz & PROGRESSIVE SCAN

Contents

Safety precautions	2
Cautions on screen treatment . . .	3
Setting up your TV	4
TV buttons and functions	7
Remote control buttons and functions	8
Using the TV's menu	16
Basic operation	16
PICTURE SETTING menu	17
PICTURE FEATURES menu	18
SOUND SETTING menu	20
FEATURES menu	21
INSTALL menu	23
Additional preparation	27
Troubleshooting	30
Specifications	Back cover

INSTRUCTIONS

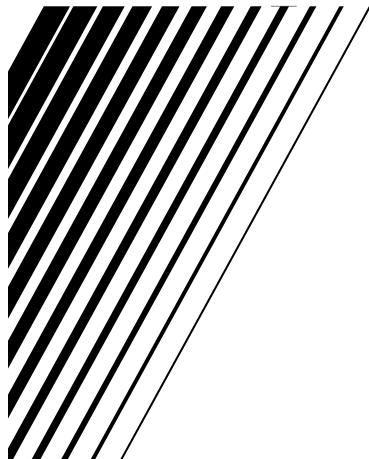

Thank you for buying this JVC colour television.

To make sure you understand how to use your new TV, please read this manual thoroughly before you begin.

Safety precautions

WARNING:

TO PREVENT FIRE OR SHOCK HAZARD, DO NOT EXPOSE THIS APPLIANCE TO RAIN OR MOISTURE.

CAUTION:

TO ENSURE PERSONAL SAFETY, OBSERVE THE FOLLOWING RULES REGARDING THE USE OF THIS TV.

- 1 Operate only from the power source indicated on the rear of the TV.
- 2 Avoid damaging the power cord and mains plug. When unplugging the TV, grasp the mains plug. Do not pull on the power cord.
- 3 Never block or cover the ventilation openings. Never install the TV where good ventilation is unattainable.

When installing this TV, leave spaces for ventilation around the TV of more than the minimum distances as shown.

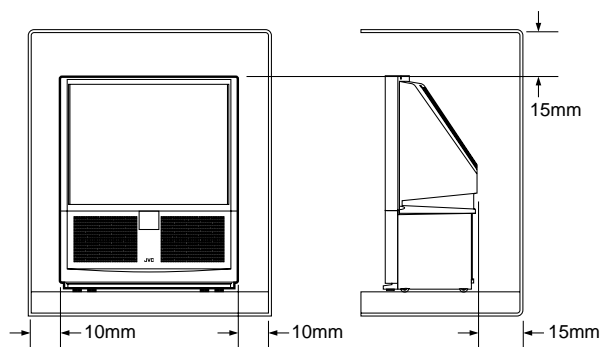

- 4 Do not allow objects or liquid into the cabinet openings.
- 5 In the event of a fault, unplug the unit and call a service technician. Do not attempt to repair it yourself or remove the rear cover.
- 6 If you are not going to use this TV for a long period of time, be sure to disconnect the AC plug from the AC socket.
- 7 This TV set is mounted on casters which make it easier to move. However, when positioning or moving the TV, observe the following cautions:
 - Do not position the TV on a slanting or unstable place.
 - Do not use excessive force, which could damage the TV, or even overturn the TV, breaking it and possibly injuring someone.
 - To avoid overturning the TV, which could injure someone, secure it in place using the method described next page.
 - Before moving the TV, unplug the plug from the AC socket, and be sure to disconnect ALL of the cables connecting the TV to external device.
 - There must be at least 8 mm between the bottom of the TV and the floor.

When moving the TV, make sure that the bottom of the TV does not scrape along the floor.

In addition, be careful when moving the TV across thick carpets, bumps in the floor, or other changes in floor level (such as at the edges of carpets). Be especially careful that the TV or the caster wheels do not catch on anything. If the TV falls over, the TV will break and could injure someone.

To prevent the TV from falling over:

Use the two small plastic loops on the back of the TV set, and connect them to a wall or column using two secure wires or strong cords.

- The wire or strong cord, and wall ring (or similar attachment), are not supplied with this TV set. Use commonly available items, but make sure that they are strong.
- The thread or wire should be straight.
- Make sure that the wire or strong cords is taut and security attached to a wall ring (or similar attachment).

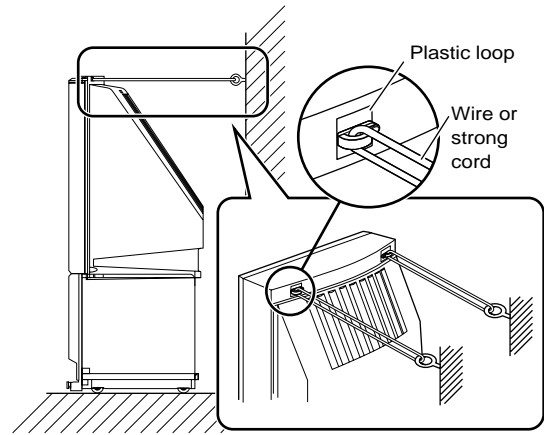

Cautions on screen treatment

Screen Burn:

Screen burn will only happen if you misuse the TV, and therefore damage from screen burn is not covered by the warranty. Screen burn happens when images remain on the screen without moving for an extended period of time. Screen burn can occur in any projection television made by any manufacturer.

You may have seen screen burn on ATM bank machines. People who use “screen savers” on their computer monitors are saving their monitors from screen burn. Especially for projection TV’s screen burn is caused by programmes or images displayed when the TV has a high CONTRAST or BRIGHTNESS setting.

- Do not play video games, computer programme, or similar programmes that have fixed or repetitive images.
- Keep contrast and brightness low – especially on teletext programmes, news programmes, business reports, and home-shopping (or similar) programmes. To adjust contrast and brightness, see page 17.
- Do not leave fixed images on the screen for long time.

Screen Cleaning:

Your projection television screen is fragile and should be handled with extreme care, especially if you are forced to touch the screen directly – i.e. when cleaning it. Be careful not to scratch the screen with jewellery or fingernails.

The following products will DAMAGE THE SCREEN. Do not use them under any circumstances.

- **AMMONIA.** NEVER use detergents that contain ammonia !
- **AEROSOLS AND CHEMICALS.** NEVER use aerosol or chemical cleaners !
- **GLASS AND WINDOWS CLEANERS.** NEVER use glass or windows cleaners !

To clean the screen:

Clean the screen *only* with a solution consisting of water and mild dish detergent.

1. Add two to three drops of detergent to one quart of water.
2. Take a soft cloth (such as a cotton tee-shirt), dampen the cloth with the soapy solution, and *gently* wipe the screen from top to bottom.
3. Gently wipe off any soap left on the screen.

Setting up your TV

CAUTION

- Turn off all the equipment including the TV before connecting anything.

1 Connecting the aerial and VCR

- Aerial cable is not supplied. Use a good quality 75-ohm coaxial cable.
- Read the manual that came with the VCR before connecting.

If not connecting a VCR (see fig.A) :

Connect an aerial cable to the aerial socket on this TV .

If connecting a VCR (see fig.B) :

- 1 Connect the aerial cable to the aerial input socket on the VCR, and connect the VCR and TV with another aerial cable.
- 2 Connect the VCR's VIDEO OUT (video output) jack and the TV's VIDEO jack with a video cable.

To connect a VCR to the TV with an S-VIDEO cable:
Connect the VCR's S-VIDEO OUT (S-VIDEO output) connector and TV's S connector with an S-VIDEO cable (A) , instead of connecting with a video cable.

- 3 Connect the VCR's VIDEO OUT (audio L/R output) jacks and the TV's AUDIO jacks (L/MONO and R) with an audio cable.

- If the VCR's audio output is in mono, connect the VCR's AUDIO OUT (audio output) jack and the TV's AUDIO L/MONO jack with an audio cable.
- You can use the AV COMPU LINK function if your VCR has an AV COMPU LINK terminal. For details, see "Connecting AV COMPU LINK Supported Devices" on page 29.

2 Connecting the power cord

Connect the mains plug to the AC outlet.

3 Putting the batteries into the Remote control

Use two AA/R6 batteries.

Insert the batteries from the ⊖ end, making sure the ⊕ and ⊖ polarities are correct.

- Follow the warnings printed on the batteries.
- If the remote control does not work properly, replace the batteries.
- The batteries we supply are only for setting up and testing your TV. Please replace them as soon as necessary.

Fig.A

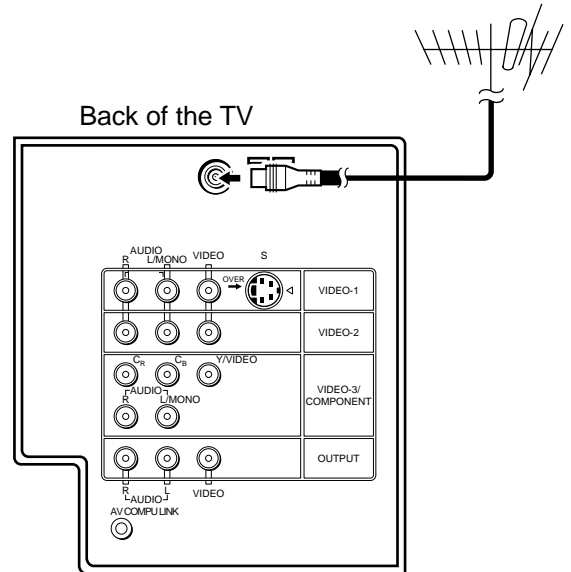
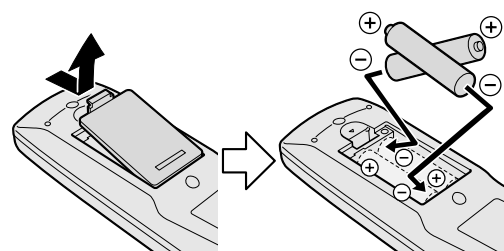
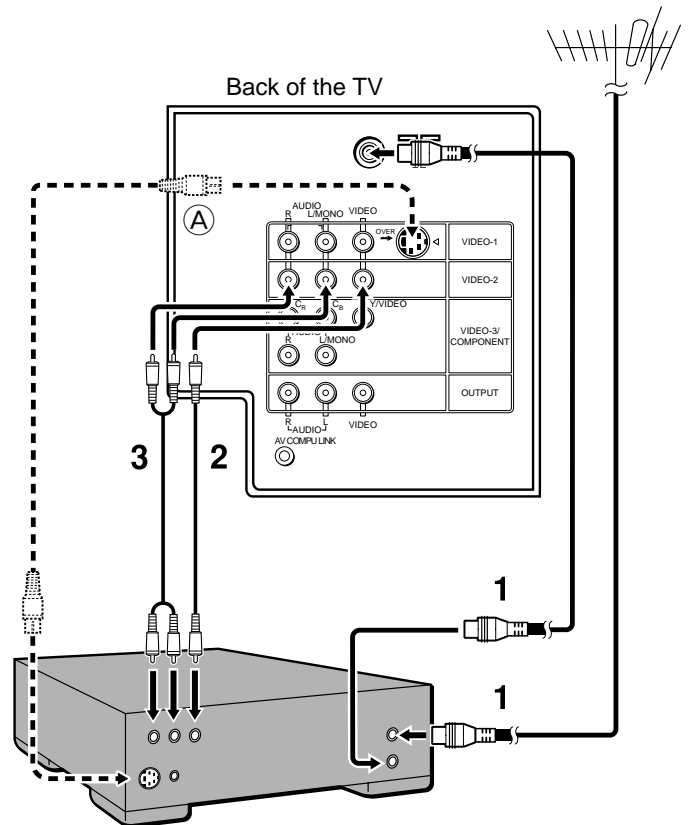

Fig.B



4 Making the initial settings

When the TV is first turned on, it enters the initial setting mode, and the JVC logo is displayed.

1 Press the main power button on the TV

The TV is turned on, and the JVC logo appears.

- If the power lamp on the TV lights red and does not change to green, your TV is in the standby mode. Press the POWER button on the remote control to turn the TV on.
- If the JVC logo does not appear, your TV has already been turned before. In this case, use the "LANGUAGE" and "AUTO PROGRAM" functions to make the initial settings. For details, see "INSTALL menu" on page 23.

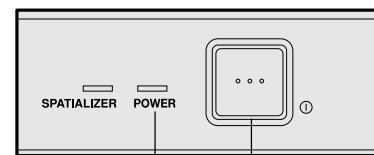
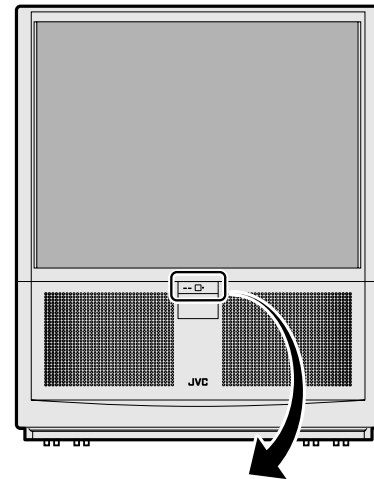

POWER lamp

Main power button

2 Press the MENU/OK button

The LANGUAGE menu appears. You can choose a language for the on-screen language.

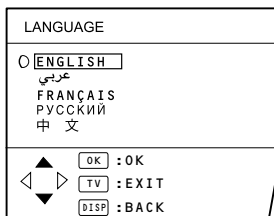

3 Press the ▲/▼ buttons to choose ENGLISH. Then press the MENU/OK button.

The AUTO PROGRAM function starts. The TV channels you receive are automatically stored in the programme numbers list.

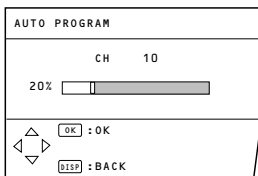

- To cancel the AUTO PROGRAM function, press the DISPLAY button.

4 After the TV channels have been stored in the programme number (PR) list, the EDIT menu appears.

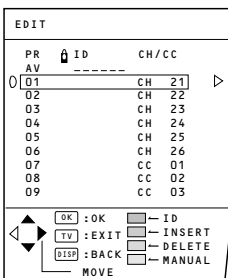

- You can proceed to edit the programme numbers list using the EDIT/MANUAL function. For details, see "EDIT/MANUAL" on page 23.
- If a TV channel you want to view is not stored in the programme numbers list, you can register it using the MANUAL function. For details, see "EDIT/MANUAL" on page 23.

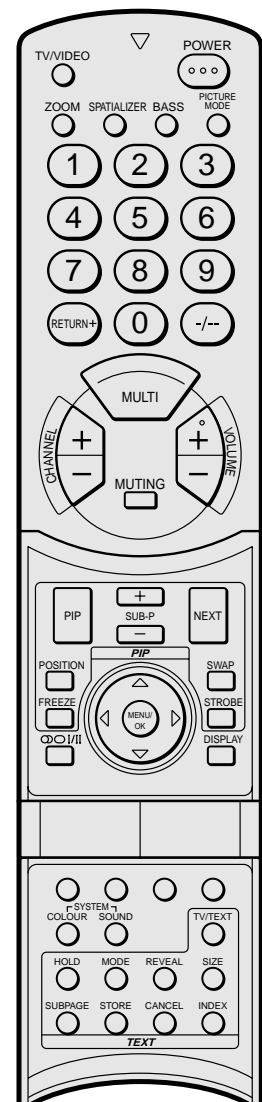
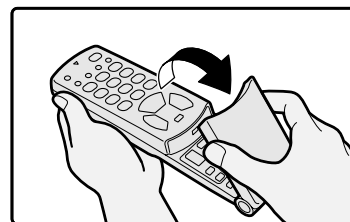

- The AUTO PROGRAM function does not store a TV channel to the programme number 0 (AV).

5 If you do not need to use the EDIT/MANUAL function, press the MENU/OK button to close the EDIT menu.

5 Adjusting CRT colour convergence

This TV has three color projection tubes : one for red, one for green and one for blue. When mixed together in the proper proportion, the output of these three colour tubes can produce any colour. To produce these colour, however, the beams must be precisely aligned over each other so that the colours can be mixed. The produce of aligning these picture beams is called "convergence".

- Colours may become separated after the TV has been moved, or over a long period of time if regularly subjected to low level vibrations.If the colours become separated, please perform the adjustment below again.

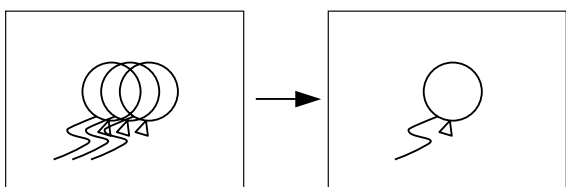

Before the convergence is adjusted

After the convergence is adjusted

1 Press the MENU/OK button.

The main menu appears.

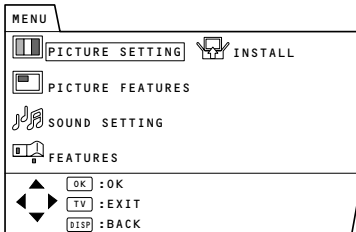

2 Press the ▲/▼ buttons to choose PICTURE FEATURES menu. Then press the MENU/OK button.

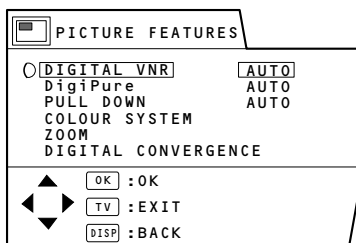

3 Press the ▲/▼ buttons to choose DIGITAL CONVERGENCE. Then press the MENU/OK button.

The convergence adjustment screen appears with crosses (+) displayed in 9 locations.

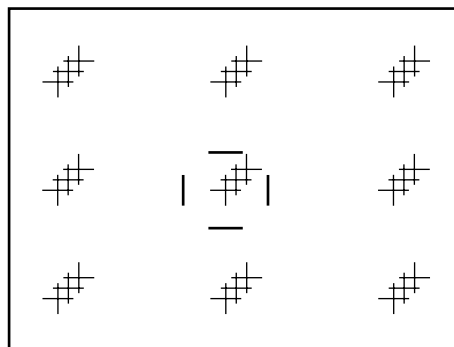

Locations where the crosses appear in 3 colours: Convergence adjustment is required. Perform steps 4 and 5.

Locations where the crosses are white: The convergence is adjusted correctly.

- If all the crosses are white, no convergence adjustment is needed.

4 Use the number buttons on the remote control to select the location to be adjusted.

The locations of the crosses correspond to the positions of the number buttons on the remote control. A box appears around the selected cross.

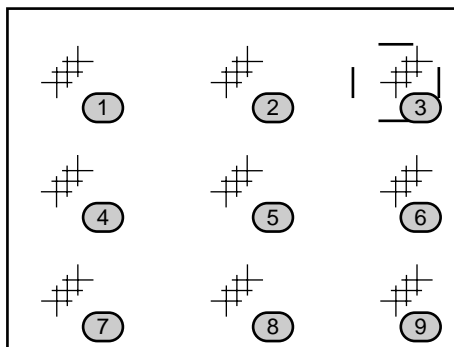

5 Adjust the three coloured crosses until they overlap and appears as a single (white) cross.

1. Press the NEXT button to change the colour of the box to the colour of the cross you want to adjust (red or blue).

- You cannot adjust the green cross.

2. Use the ▲/▼ and ◀/▶ buttons to adjust the position of the cross.

To cancel the adjustments before completing the procedure: Press the DISPLAY button.

6 Press the MENU/OK button to end the convergence adjustment procedure.

- If you do not use the TV controls for roughly one minute, the convergence adjustment screen automatically disappears.

Now, the setting up is complete.

Please enjoy your new JVC TV!

TV buttons and functions

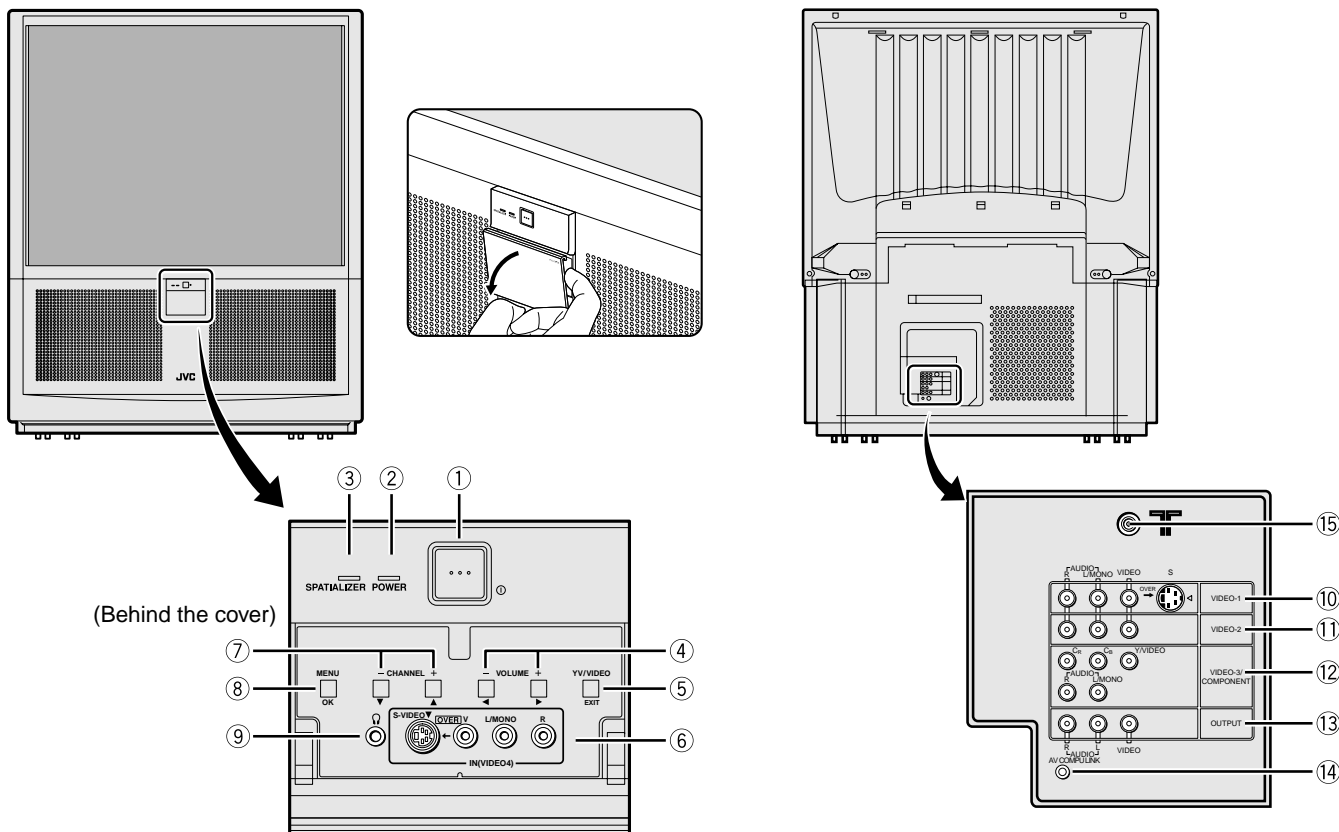

Turn the main power on

Press the main power button ① .

The POWER lamp ② lights red and your TV is in the standby mode.

To turn the main power off :
press the main power button again.
The POWER lamp ② goes off.

Turn the TV on from standby mode

Press the CHANNEL-/+ buttons ⑦ .

The POWER lamp ② lights red to green and your TV will be turned on.

- You can also turn on the TV by pressing the TV/VIDEO button ⑤ while it is in standby mode.

Choose a TV channel

Press the CHANNEL-/+ buttons ⑦ .

Choose a VIDEO terminal

Press the TV/VIDEO button ⑤ or CHANNEL -/+ buttons ⑦ .

Adjust the volume

Press the VOLUME-/+ buttons ④ .

The volume level indicator appears.

MENU button ⑧

Press to open the menu.

For details, see "Operation with the buttons on the TV" on page 16.

SPATIALIZER lamp ③

If you set the SPATIALIZER function to MONO or LIVE, the SPATIALIZER lamp lights.

Headphone jack ⑨

Connect the headphones with a stereo mini-jack (3.5mm in diameter).

When using the headphones, follow the operation procedure "HEADPHONE" on page 20.

VIDEO-1 terminal ⑩

- See page 4 and 27.

VIDEO-2 terminal ⑪

- See page 27.

VIDEO-3/COMPONENT terminal ⑫

- See page 22 and 27.

VIDEO-4 terminal ⑬

- See page 27.

OUTPUT terminal ⑬

- See page 27.

AV COMPU LINK terminal ⑭

- See page 27 and 29.

Aerial socket ⑮

Connect the aerial cable.

- See page 4.

Remote control buttons and functions

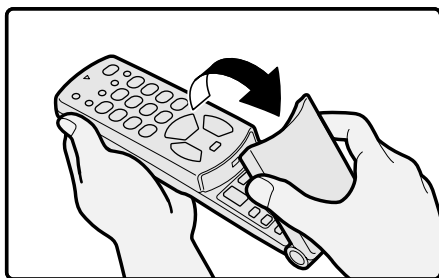

Turn the TV on from standby mode

Press the POWER button.

The POWER lamp lights red to green and your TV will be turned on.

- You can turn on the TV from the standby mode by pressing the TV/VIDEO button, the CHANNEL +/- buttons or the number buttons.

To turn the TV off:

Press the POWER button again.

The POWER lamp changes from green to red and the TV enters standby mode.

Choose a TV channel

Choose a programme number in which a TV channel has been set.

Press the CHANNEL +/- buttons or enter the programme number (PR) with the number buttons.

- If you want to put a two-digit channel into the TV, press the -/--button to change to the two-digit entry system.
- You can select a channel from the PR LIST. For details, see "DISPLAY button" on page 10.
- If you do not have a clear picture or no colour appears, follow the operation procedure "COLOUR SYSTEM button" on page 11.
- If you cannot hear sound normally even when the picture appears normally, follow the operation procedure "SOUND SYSTEM button" on page 11.

Adjust the volume

Press the VOLUME +/- buttons.

- You cannot adjust the volume of your headphones. Follow the operation procedure "HEADPHONE" on page 20.

Watch images from external devices

Choose a VIDEO terminal to which the external device has been connected.

Press the TV/VIDEO button.

- You can choose a VIDEO terminal with the CHANNEL +/- buttons or from the PR LIST.

To return to a TV channel:

Press the TV/VIDEO button, the CHANNEL +/- buttons or the number buttons.

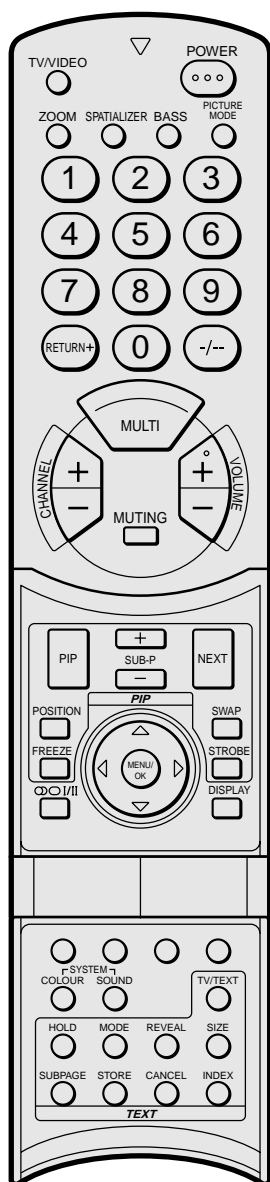

MUTING button

Press the MUTING button to turn off the volume. Pressing the MUTING button again resumes the previous volume level.

- When the TV's MUTING function is on,  is displayed on the screen. However, to prevent screen burn-in, the mark automatically dims if no TV operation has been performed for a period of about one minute.

ZOOM button

You can change the screen size according to the picture aspect ratio. Choose the optimum one from the following ZOOM modes.

Press the ZOOM button to choose a mode.

- If you press the ZOOM button when receiving the Progressive Video Signal (525P signal), "525P" appears on the screen and the ZOOM function does not operate.

REGULAR :

Use to view a normal picture (4:3 aspect ratio) as its original size is.

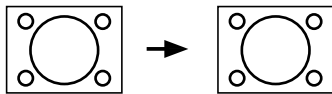

ZOOM :

You can zoom up the Wide picture (16:9 aspect ratio) to fill the TV screen.

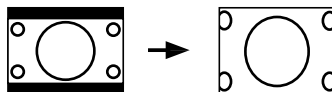

- The left side and right side of the Wide picture (16:9 aspect ratio) will be cut off.

SPATIALIZER button

You can enjoy Surround sound with a "live" effect by using the SPATIALIZER function.

Press the SPATIALIZER button to choose a mode.

LIVE :

Live allows you to enjoy normal stereo sound converting it into surround sound with added depth and ambience.

MONO :

Mono allows you to enjoy normal monaural sound by converting it into a stereo-like sound.

OFF :

This function is turned off.

- The LIVE mode works properly only with stereo sound.
- The LIVE mode does not work correctly with headphones.
- The MONO mode works properly only with monaural sound.

The SPATIALIZER is manufactured under license from Desper Products, Inc.

BASS button

You can enjoy a powerful bass sound by using the SUPER BASS (Super Bass Reflex) function.

Press the BASS button to turn the SUPER BASS function on or off.

ON :

This function is turned on.

OFF :

This function is turned off.

PICTURE MODE button

You can choose one of three PICTURE MODEs (three kinds of picture setting) to adjust the picture settings automatically.

Press the PICTURE MODE button choose a mode.

BRIGHT :

Heightens contrast and sharpness.

STANDARD :

Standardizes picture adjustment.

SOFT :

Softens contrast and sharpness.

RETURN+ button

The RETURN+ button has two functions; the RETURN+ function and the RETURN function. If a channel has been registered as the "Return Channel", the RETURN+ function operates. If there is no setting for the "Return Channel", the RETURN function operates.

RETURN+ function :

By registering a channel you frequently view as the "Return Channel", you can select that channel at any time simply by pressing the RETURN+ button.

To register a TV channel as the "Return Channel" :
Choose the Programme number to which the channel you want to register has been set, and press the RETURN+ button and hold for more than 3 seconds continuously. "RETURN PLUS PROGRAMMED!" is displayed and the registration is completed.

To cancel register a TV channel as the "Return Channel" :

while viewing any TV channel, press the RETURN+ button and hold for more than 3 seconds continuously. "RETURN PLUS CANCELED!" is displayed and the registration is cancelled.

- When you turn off the TV, the registration for the "Return Channel" is cancelled.
- If you want to view the "Return Channel" and another TV channel alternately, first choose a channel other than the "Return Channel". and then press the RETURN+ button to change the channel to the "Return Channel". In this way, you can view two channels alternately by pressing the RETURN+ button.

RETURN function :

The TV temporarily memorises the TV channel that was chosen right before the current TV channel as the "Last Channel". By pressing the RETURN+ button, you can alternately view the current TV channel and the "Last Channel".

- If you want to view two channels alternately by using the RETURN function, first choose one TV channel and then choose the other TV channel with the Number buttons. If you choose the TV channel without using the Number buttons, there are cases where a channel other than the one you first chose is registered as the "Last Channel".

∞ ○ I/II button

When you are viewing a bilingual broadcast programme, you can choose the sound from Bilingual I (Sub I) or Bilingual II (Sub II). When the stereo broadcasting is received poorly, you can change from stereo to mono sound so that you can hear the broadcast more clearly and easily.

Press the ∞ ○ I/II button to choose a sound mode.

- ∞ : Stereo sound
- : mono sound
- I : Bilingual I (sub I)
- II : Bilingual II (sub II)

MONO : Cancels the Multi Sound function, and the sound becomes monaural.

- The sound mode you can choose differs depending on the TV programme.
- This function does not work in the VIDEO modes.

DISPLAY button

You can display the PR LIST, programme number or VIDEO terminal number on the screen.

Press the DISPLAY button.

Press the DISPLAY button changes the display as follows:

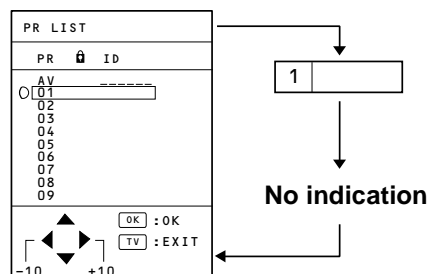

- To prevent screen burn-in, the PR LIST menu automatically disappears from the screen if no TV operation has been performed for a period of about one minute. Also, the programme number and VIDEO terminal number automatically dim.

Choose a TV channel or a VIDEO terminal

- 1 Press the DISPLAY button to display the PR LIST.
- 2 Press the ▲/▼ and ◀/▶ buttons to choose a programme number or VIDEO terminal. Then press the MENU/OK button.
 - For programme numbers with the CHANNEL GUARD function set, the  (CHANNEL GUARD) mark is displayed next to the programme number in the PR LIST.
 - The VIDEO terminals are registered after the programme number PR99.

COLOUR SYSTEM button

The colour system is chosen automatically. However, if the picture is not clear or no colour appears, choose the colour system manually.

Press the **COLOUR SYSTEM** button to choose the appropriate colour system.

AUTO :

This function detects a colour system from the input signal.

- The AUTO mode may not function properly if you have poor signal quality.
If the picture is abnormal in the AUTO mode, choose another colour system manually.
- The AUTO mode detects a colour system from the input signal and chooses the appropriate colour system automatically.
- When changing the COLOUR SYSTEM of the SUB-picture, see "Change the colour system of the SUB-picture" on page 13 for details.
- For the colour systems in each country or region, see the table "BROADCASTING SYSTEMS" on page 11.

SOUND SYSTEM button

The sound system is chosen automatically. However, if you cannot hear the sound normally even when the picture appears normally, choose the sound system manually.

Press the **SOUND SYSTEM** button to choose the appropriate sound system.

B/G : B/G system

I : I system

D/K : D/K system

M : M system

- This function does not work in the VIDEO mode.
- For the sound systems in each country or region, see the table "BROADCASTING SYSTEMS" on page 11.

BROADCASTING SYSTEMS

For sound system colour system in your country or region, refer to the table below.

COLOUR SYSTEM

Area	Country or Region	System
Asia, Middle East	Bahrain, Kuwait, Oman, Qatar, United Arab Emirates, Yemen, etc. Indonesia, Malaysia, Singapore, Thailand, India, etc.	PAL
	China, Vietnam, etc	PAL
	Hong Kong, etc	PAL
	Islamic Republic of Iran, Lebanon, Saudi Arabia, etc.	SECAM
	Philippines, Taiwan, Myanmar, etc	NTSC
Europe	Russia, etc	SECAM
	Czech Republic, Poland, etc	PAL
	Germany, Holland, Belgium, etc	PAL
	UK, etc	PAL
Oceania	Australia, New Zealand, etc	PAL
Africa	Republic of South Africa, etc	PAL
	Nigeria, etc	PAL
	Egypt, Morocco, etc	SECAM

SOUND SYSTEM

Area	Country or Region	System
Asia, Middle East	Bahrain, Kuwait, Oman, Qatar, United Arab Emirates, Yemen, etc. Indonesia, Malaysia, Singapore, Thailand, India, etc.	B/G
	China, Vietnam, etc	D/K
	Hong Kong, etc	I
	Islamic Republic of Iran, Lebanon, Saudi Arabia, etc.	B/G
	Philippines, Taiwan, Myanmar, etc	M
Europe	Russia, etc	D/K
	Czech Republic, Poland, etc	D/K
	Germany, Holland, Belgium, etc	B/G
	UK, etc	I
Oceania	Australia, New Zealand, etc	B/G
Africa	Republic of South Africa, etc	I
	Nigeria, etc	B/G
	Egypt, Morocco, etc	B/G

FREEZE button

You can view the Main picture's frozen image as the SUB-picture.

Press the FREEZE button.

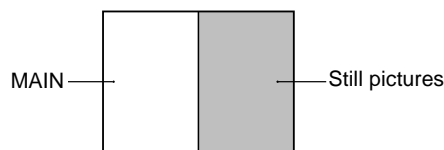

To cancel the FREEZE function :

Press the FREEZE button again.

- You cannot use the FREEZE button when the SUB-picture or the MAIN-picture are displayed on the screen.
- If you press the FREEZE button when receiving the Progressive Video Signal (525P signal), "525P" appears on the screen and the FREEZE function does not operate.
- Compared to the normal picture the two pictures are vertically elongated.
- To prevent screen burn-in, the FREEZE function is automatically cancelled if no TV operation has been performed for a period of about 15 minutes.

STROBE button

You can view the MAIN-picture as 15 consecutive still images.

Press the STROBE button.

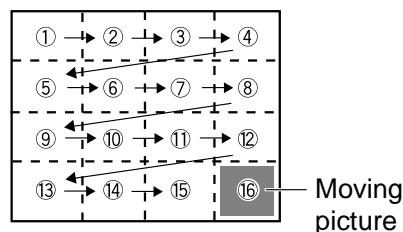

To cancel the STROBE function:

Press the STROBE button to return to the MAIN-picture.

- If signal level of the MAIN-picture is weak, the still images become abnormal.
- You cannot use the STROBE button when the SUB-picture or the MAIN-picture are displayed on the screen.
- If you press the STROBE button when receiving the Progressive Video Signal (525P signal), "525P" appears on the screen and the STROBE function does not operate.
- You cannot change the TINT setting for the still images on the screen even if you are viewing a programme with NTSC colour system.
- To prevent screen burn-in, the screen automatically dims if no TV operation has been performed for a period of about 15 minutes.

Using the MULTI function

You can display multi-pictures that enable you to easily find a program you want to view.

1 Press the MULTI button.

Press the MULTI button changes the display as follow:

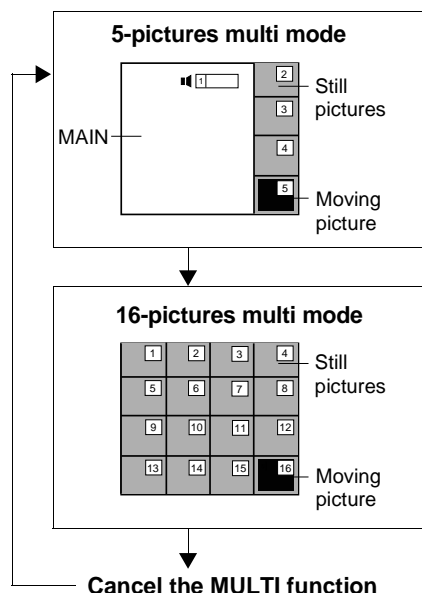

To display next Multi pictures :

Press the NEXT button.

2 Choose the desired picture with the ▲/▼ and ◀/▶ buttons, and then press the MENU/OK button.

The screen switches to the TV channel or VIDEO mode of your choice.

- Any programme numbers to which no TV channel has been registered, or programme numbers to which CHANNEL GUARD has been set is not displayed.
- You cannot perform menu operations such as headphone volume adjustment. Cancel the MULTI function once to perform menu operations.
- If you press the MULTI button when receiving the Progressive Video Signal (525P signal), "525P" appears on the screen and the MULTI function does not operate.
- During the short period that is required for the Multi-pictures display to close no sound comes from the television.

■ Using the PIP function

You can view two pictures (MAIN and SUB) at the same time.

Press the PIP button.

Press the PIP button changes the display as follows:

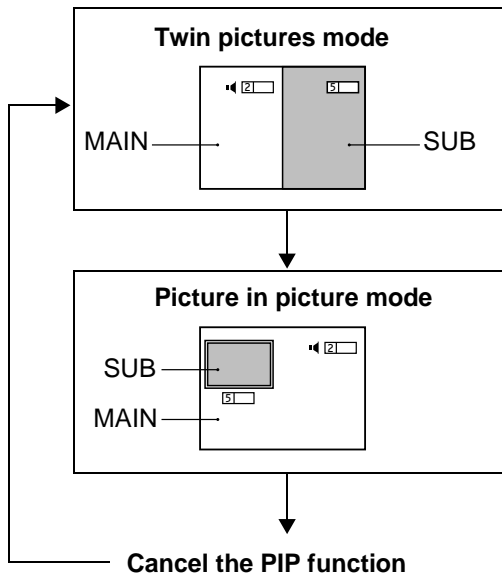

- You cannot view a picture from the same programme number (or the same VIDEO terminal) as both the MAIN-picture and the SUB-picture at the same time.
- If the MAIN-picture signal is poor, then the quality of the SUB-picture may also be poor.
- If the picture standards of both pictures are different, the top and bottom or one of them may be missing.
- The ZOOM function does not operate when viewing pictures using the PIP function.
- The SUB-picture cannot be output from TV.
- If you press the PIP button when receiving the Progressive Video Signal (525P signal), "525P" appears on the screen and the PIP function does not operate.
- In Twin pictures mode, compared to the normal picture the two pictures are vertically elongated.

Choose a TV channel for the SUB-picture

Press the SUB-P +/- button.

Listen to the sound of SUB-picture

You can listen to the sound of SUB-picture on your headphones while listening to the sound of MAIN-picture on the TV speakers. For details, see "HEADPHONE" on page 20.

Change the colour system of the SUB-picture

- 1 While the SUB-picture is displayed, press the MENU/OK button to display the MENU (main manu).
- 2 Press the ▲/▼ and ◀/▶ buttons to choose PICTURE FEATURES, and then press the MENU/OK button.
- 3 Press the ▲/▼ buttons to choose COLOUR SYSTEM, and then press the MENU/OK button.

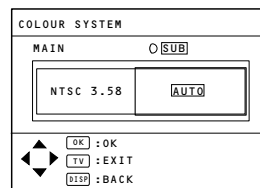

- 4 Press the ◀/▶ buttons to choose SUB, and then press the ▲/▼ buttons to choose the appropriate colour system. Then press the MENU/OK button.

- You cannot change the COLOUR SYSTEM of the SUB-picture using the COLOUR SYSTEM button on the remote control.

POSITION button

You can adjust the position of the SUB- Picture when using the Picture in picture mode.

Press the POSITION button repeatedly.

Each time you press the button, the SUB- Picture moves counterclockwise.

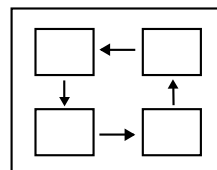

SWAP button

You can replace the MAIN-picture and the SUB-picture with each other.

Press the SWAP button.

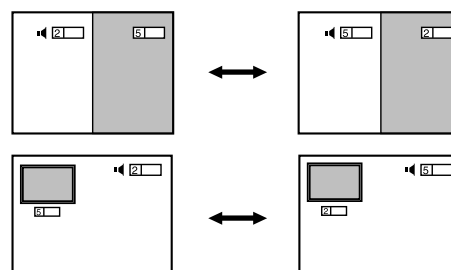

- Do not press the SWAP button while you are recording the TV output on the VCR. If you do, the output signal will change.

■ Viewing a teletext programme

- 1 Choose a TV channel with a teletext broadcast.
- 2 Press the TV/TEXT button.
Press the TV/TEXT button changes the mode as follows:

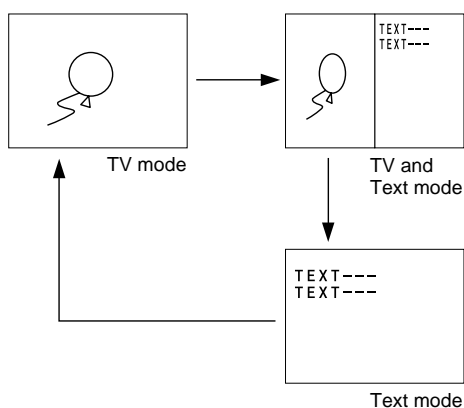

- 3 Choose a teletext page by pressing the CHANNEL-/+ buttons, number buttons or coloured buttons.

To return to the TV mode:

Press the TV/TEXT button or TV/VIDEO button.

- If you have trouble receiving teletext broadcasts, consult your local dealer or the broadcast station.
- In the Text mode, the ZOOM mode is fixed to the REGULAR mode.
- No menu operations are possible when viewing a teletext programme.
- If characters on a teletext programme do not appear properly, change the TELETEXT LANGUAGE setting. For details, see "TELETEXT LANGUAGE" on page 26.
- In TV and Text mode, compared to the normal picture the two pictures are vertically elongated.

HOLD button

You can hold a teletext page on the screen for as long as you want, even while several other teletext pages are being received.

Press the HOLD button.

The  (hold) are displayed at the top left of the screen.

To cancel the Hold function:

Press the HOLD button again.

REVEAL button

Some teletext pages include hidden text (such as answers to a quiz).

You can display the hidden text.

Each time you press the REVEAL button, text is hidden or revealed.

SIZE button

You can double the height of teletext display.

Press the SIZE button.

INDEX button

You can return to the index page instantly.

Press the INDEX button.

- In the List mode, you can return to the page number displayed in the lower left area of the screen.

CANCEL button

You can search for a teletext page while watching TV.

- 1 Press the number button to enter a page number, or press the coloured button.

The TV searches for a teletext page.

- 2 Press the CANCEL button.

The TV programme appears. When the TV finds the teletext page, its page number appears in the upper left of the screen.

- 3 Press the CANCEL button to return to a teletext page when the page number is on the screen.

- You cannot return to the TV mode with the CANCEL button.

SUBPAGE button

Some teletext pages include sub-pages that are automatically displayed. You can hold any sub-page, or view it at any time.

1 Press the SUBPAGE button to operate the Sub-page function.

Sub-page numbers are displayed at the left of the screen.

Colour*	Meaning of sub-page number
Yellow	Currently being displayed.
White	Can be displayed.
Blue or Red	Cannot be displayed and it is not sent.

* : Background color of the sub-page number.

2 Press the CHANNEL-/+ buttons to choose a sub-page number.

To cancel the Sub-page function:

Press the SUBPAGE button again.

Using the List mode

You can store the numbers of your favourite teletext pages in memory and call them up quickly using the coloured buttons.

To store the page numbers :

1 Press the MODE button to engage the List mode.

The stored page numbers are displayed at the bottom of the screen.

2 Press a coloured button to choose a position. Then press the number buttons to enter the page number.

3 Press and hold down the STORE button.

The four page numbers blink white to indicate that they are stored in memory.

To call up a stored page :

1 Press the MODE button to engage the List mode.

2 Press a coloured button to which a page has been assigned.

To exit the List mode :

Press the MODE button again.

Using the TV's menu

This TV has a number of functions you can operate using menus. To fully utilize all your TV's functions, you need to understand the basic menu operating techniques fully.

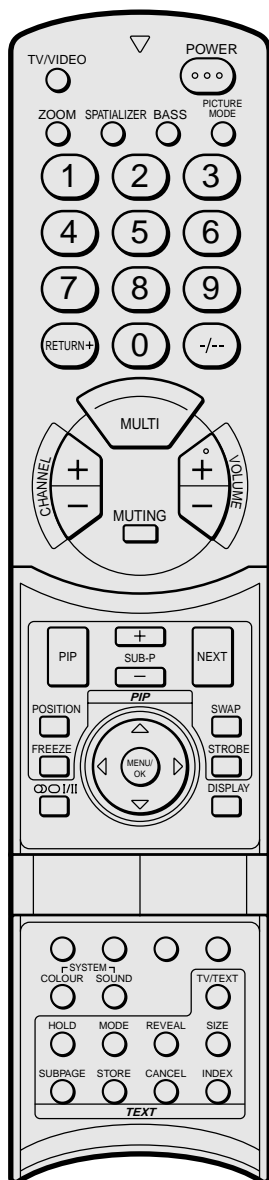
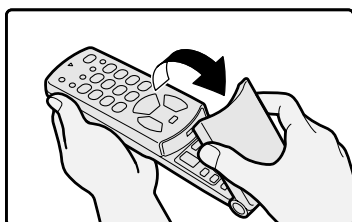

(Behind the cover)

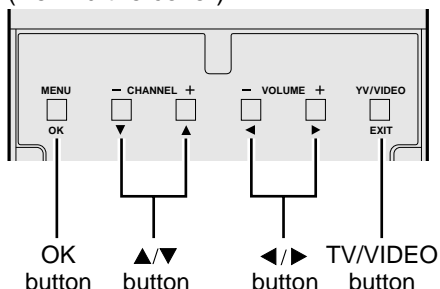

Basic operation

1 Press the MENU/OK button to display the MENU (main menu).

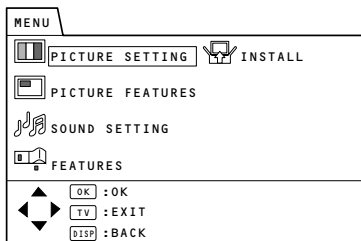

- To prevent screen burn-in, the menu automatically disappears from the screen if no TV operation has been performed for a period of about one minute.
- The display appearing at the bottom of a menu indicates buttons on the remote control you can use when you operate a chosen function.

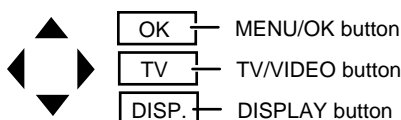

2 Press the ▲/▼ and ◀/▶ buttons to choose a menu title, and press the MENU/OK button.

The menu appears.

To return to the previous menu:
Press the DISPLAY button.

To exit a menu instantly:
Press the TV/VIDEO button.

3 Press the ▲/▼ buttons to choose a function.

- For details of the functions in the menus, see the following pages.

4 Press the ◀/▶ buttons to choose the setting of that function.

- If you want to operate a function which appears only with its name, follow the descriptions of that function on the following pages.

5 Press the MENU/OK button to complete the setting.
The menu disappears.

- When watching the television with the NTSC system, the menus are displayed at about half of their normal vertical size.

Operation with the buttons on the TV

You can also operate the menus using the buttons on the front panel of the TV.

- There is no button on the front panel of the TV that has the function of the DISPLAY or coloured buttons.

PICTURE SETTING menu

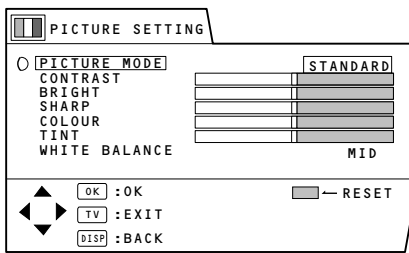

PICTURE MODE

You can choose one of three PICTURE MODEs to adjust the picture settings automatically.

BRIGHT:

Heightens contrast and sharpness.

STANDARD:

Standardizes picture adjustment.

SOFT:

Softens contrast and sharpness.

- You can also operate the PICTURE MODE function with the PICTURE MODE button on the remote control. For details, see "PICTURE MODE button" on page 9.

Adjusting the picture

You can change the picture settings of each picture mode as you like. The picture settings changed are stored in the picture mode.

CONTRAST

You can adjust the picture contrast.

- ◀ : lower
- ▶ : higher

BRIGHT

You can adjust the picture brightness.

- ◀ : darker
- ▶ : brighter

SHARP

You can adjust the picture sharpness.

- ◀ : softer
- ▶ : sharper

- You cannot select the SHARP function when receiving the Progressive Video Signal (525P signal).

COLOUR

You can adjust the picture colour.

- ◀ : lighter
- ▶ : deeper

TINT

You can adjust the picture tint.

- ◀ : reddish
- ▶ : greenish

- You can change the TINT setting (picture tint) only when the colour system is NTSC 3.58 or NTSC 4.43.
- You cannot select the TINT function when receiving the Progressive Video Signal (525P signal).

To return to the default settings in each PICTURE MODE :
Press the blue button. Returns the picture settings in the currently chosen PICTURE MODE mode to the default settings, and stores them in the PICTURE MODE again.

WHITE BALANCE

You can select one of three WHITE BALANCE modes (three tones of white) to adjust the white balance of the picture. Since white is the colour which is used as a reference for all the other colours, changing the WHITE BALANCE mode affects the appearance of all the other colours on the screen.

COOL:

A bluish white. Using this mode when watching bright pictures allows you to enjoy a more vivid and bright picture.

MID:

The normal white colour.

WARM:

A reddish white. Using this mode when watching films allows you to enjoy colours that are characteristic of films.

- You cannot select the WHITE BALANCE function in the Twin pictures mode.

PICTURE FEATURES menu

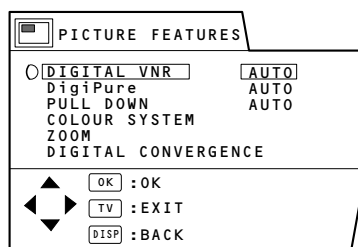

■ DIGITAL VNR

The DIGITAL VNR function cuts down the amount of noise in the original picture.

- You cannot select the DIGITAL VNR function when receiving the Progressive Video Signal (525P signal).

AUTO:

The TV will be automatically adjust the level of the DIGITAL VNR effect to match the amount of noise in the picture, giving you the best possible picture.

- If you set the DIGITAL VNR effect too high it can make the picture less sharp. It is recommended to use the AUTO setting if you can.

MAX:

The level of the DIGITAL VNR effect is set to the maximum. If you set the DIGITAL VNR function to AUTO but still notice some noise, change the setting from AUTO to MAX.

- The MAX setting is not suitable for high-quality pictures which contain a lot of noise.

MIN:

The level of the DIGITAL VNR effect is set to the minimum. If you set the DIGITAL VNR function to AUTO but feel that the sharpness of the original picture has not been reproduced fully, change the setting from AUTO to MIN.

- The MIN setting is not suitable for low-quality pictures which contain a lot of noise.

■ DigiPure

The DigiPure function uses the latest in digital technology to give you a natural looking picture. The DigiPure function includes the following two functions.

Digipure function:

This function helps to create a natural looking picture by eliminating unnecessary edges from high-contrast and crisp images. Conversely, for images with low-contrast, edges are added to produce a sharper, more detailed picture.

You can choose from the DigiPure function settings of AUTO, MIN and MAX.

Picture motion

compensation function:

This function displays fast-moving pictures (for example, the players or ball in a football game) more smoothly and naturally on the screen.

- You cannot select the DigiPure function when receiving the Progressive Video Signal (525P signal).

AUTO:

The TV will automatically adjust the level of the DigiPure effect to match the amount of noise in the picture, giving the best possible picture.

- If you set the DigiPure effect too high on a low-quality picture that contains a lot of noise, this may actually make the noise worse. It is recommended to use the AUTO setting if you can.

MAX:

The level of the DigiPure effect is set to the maximum. If you set the DigiPure function to AUTO but feel that the original picture quality has not been reproduced fully, change the setting from AUTO to MAX.

- The MAX setting is not suitable for low-quality pictures which contain a lot of noise.

MIN:

The level of the DigiPure effect is set to the minimum. When you set the DigiPure function to AUTO and notice some noise, change the setting from AUTO to MIN.

- The MIN setting is not suitable for high-quality pictures which contain very little noise.

OFF:

The DigiPure function is turned off.

■ PULL DOWN

The PULL DOWN function displays a cinema film picture more smoothly and naturally on the screen.

AUTO:

This function is turned on. Normally keep this function set to AUTO.

OFF:

This function is turned off.

- The motion may appear unnatural when viewing images with the NTSC colour system. To make the motion smoother, switch the PULL DOWN function from AUTO to OFF.
- You cannot select this function in the Twin pictures mode or the Picture in picture mode.

■ COLOUR SYSTEM

The colour system is chosen automatically. However, if the picture is not clear or no colour appears, choose the colour system manually.

- 1 Choose **COLOUR SYSTEM**, then press the **MENU/OK** button.

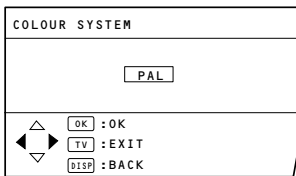

- 2 Press the **◀/▶** buttons to choose the appropriate colour system. Then press the **MENU/OK** button.

- When changing to the **COLOUR SYSTEM** of the **SUB-picture**, see "Change the colour system of the **SUB-picture**" on page 13 for details.
- You can also operate the **COLOUR SYSTEM** function with the **COLOUR SYSTEM** button on the remote control. For details, see "**COLOUR SYSTEM** button" on page 11.

■ ZOOM

You can change the screen size according to the picture aspect ratio. Choose the optimum one of two **ZOOM** modes.

- 1 Choose **ZOOM**, then press the **MENU/OK** button.

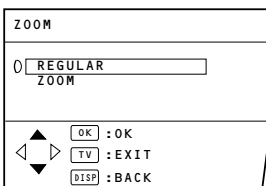

- 2 Press the **▲/▼** buttons to choose a **ZOOM** mode. Then press the **MENU/OK** button.

The picture expands and the chosen **ZOOM** mode is displayed in about 5 seconds.

- You can choose a **ZOOM** mode from **REGULAR** or **ZOOM** modes. For details, see "**ZOOM** button" on page 9.
- You cannot select the **ZOOM** function when receiving the **Progressive Video Signal (525P signal)**.

■ DIGITAL CONVERGENCE

If red, green, and blue shadows appear around the contours of the image on the screen it is necessary to adjust **CRT colour convergence**. For details, refer to "Adjusting **CRT colour convergence**" on Page 6.

SOUND SETTING menu

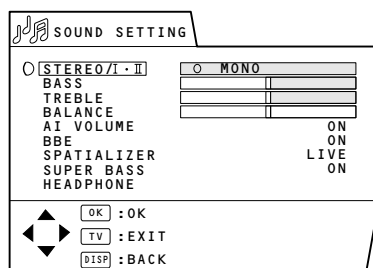

■ STEREO / I-II

When you are viewing a bilingual broadcast programme, you can choose the sound from Bilingual I (sub I) or Bilingual II (sub II). When the stereo broadcasting is received poorly, you can change from stereo to mono sound so that you can hear the broadcast more clearly and easily.

∞ : Stereo sound

○ : mono sound

I : Bilingual I (sub I)

II : Bilingual II (sub II)

MONO: Cancels the Multi Sound function, and the sound becomes monaural.

- The sound mode you can choose differs depending on the TV programme.
- This function does not work in the VIDEO modes.

■ Adjusting the sound

You can adjust the sound to your liking.

BASS

You can adjust the low tone of the sound.

- ◀ : weaker
- ▶ : stronger

TREBLE

You can adjust the high tone of the sound.

- ◀ : weaker
- ▶ : stronger

BALANCE

You can adjust the volume balance between the left and right speakers.

- ◀ : turn the left speaker's volume level up.
- ▶ : turn the right speaker's volume level up.

■ AI VOLUME

You can prevent the sudden increase or decrease of sound that occurs when changing the channel to another channel or switching the VIDEO mode to another VIDEO mode.

ON :

This function is turned on.

OFF :

This function is turned off.

- The AI VOLUME function for TV mode and VIDEO mode can be set separately. For example, you can set it to be OFF in TV mode and ON in VIDEO mode. If you set the AI VOLUME function while viewing images from a VIDEO terminal, the setting is registered as the setting for VIDEO mode.
- The AI VOLUME function may not operate as expected if the sound input level from a broadcast station (or video software) is extremely low.

■ BBE

You can use the BBE function to enjoy easy-to-listen sound that is faithful to the original sound recorded.

ON :

This function is turned on.

OFF :

This function is turned off.

Licensed by BBE Sound, inc. BBE is a registered trademark of BBE Sound, inc.

■ SPATIALIZER

You can enjoy Surround sound with a "live" effect by using the SPATIALIZER function. You can choose one of two SPATIALIZER modes.

- You can choose a SPATIALIZER mode from LIVE, MONO or OFF modes. For details, see "SPATIALIZER button" on page 9.

The SPATIALIZER is manufactured under license from Desper Products, Inc.

■ SUPER BASS

You can enjoy a powerful bass sound by using the Super Bass (Super Bass Reflex) function.

ON :

This function is turned on.

OFF :

This function is turned off.

■ HEADPHONE

This function enables you to output the TV's sound from your headphones.

- 1 Choose HEADPHONE, then press MENU/OK button.

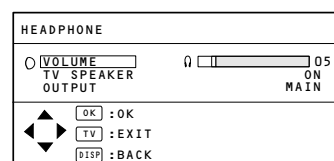

- 2 Use the ▲/▼ button to select, and the ◀/▶ button to set the HEADPHONE function. Then press the MENU/OK button.

VOLUME :

You can adjust the volume of the sound output from your headphones.

FEATURES menu

TV SPEAKER:

When this function is on, the TV's speaker does not shut off the sound even if headphones are connected.

OUTPUT:

You can choose the sound from the MAIN-picture(MAIN) or the SUB-picture(SUB) when using the headphones.

- The TV's speaker does not output the sound from the SUB-picture.
- The sound of the SUB-picture is mono only. You cannot use the STEREO/I·II function for the sound of the SUB-picture.

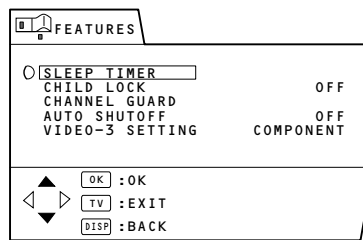

■ SLEEP TIMER

You can set the TV to automatically turn off after a set time.

- 1 Choose SLEEP TIMER, then press the MENU/OK button.

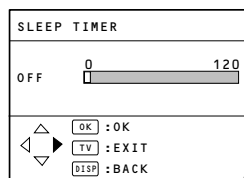

- 2 Press the ◀/▶ buttons to set the period of time.

The TV begins count down from the set time.

- You can set the period of time a maximum of 120 minutes (2 hours) in 10 minute steps.

To cancel this function:

Press the ◀ button to set a period of time to "OFF".

- 3 Press the MENU/OK button to complete the setting.

The menu disappears.

- One minute before this function turns off the TV, "GOOD NIGHT!" appears.
- This function cannot be used to turn off the TV's main power.
- When this function is on, you can display the SLEEP TIMER menu again to confirm or change the remaining time.

■ CHILD LOCK

You can disable the front control buttons of the TV. When this function is set to ON, the TV can be operated only by using the remote control.

Use this function to prevent children from operating the TV at their own discretion (without parent consent).

ON :

This function is turned on.

OFF:

This function is turned off.

■ CHANNEL GUARD

When there is a TV channel you do not want your children to watch, you can lock out the channel. Even when a child chooses a programme number for a locked out channel the screen will change to black and display  so the channel cannot be viewed.

To set this function

- 1 Choose CHANNEL GUARD, then press the number 0 (AV) button.

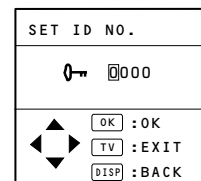

- 2 Set the ID number you want.

To choose a number:
Press the ▲/▼ buttons.

To move a cursor:
Press the ◀/▶ buttons.

3 Press the MENU/OK button.

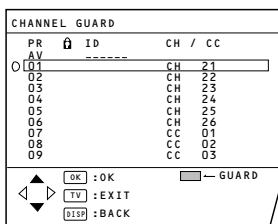

4 Press the ▲/▼ buttons to choose a TV channel.

- The TV shows the TV programme which the chosen TV channel is now broadcasting.

5 Press the blue button to set this function to the TV channel.

🔒 (CHANNEL GUARD) appears and the TV channel is locked.

To cancel this function:

Press the blue button again.

🔒 (CHANNEL GUARD) disappears and the lock is released.

6 Press the MENU/OK button to complete the setting.

The menu disappears.

To view a locked TV channel

1 Choose a programme number in which a TV channel locked with the number buttons or PR LIST.

The screen changes to black and the 🔒 (CHANNEL GUARD) appears.

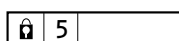

- You cannot choose a locked TV channel with the ▲/▼ buttons.

2 Press the DISPLAY button to display "ID NO." (ID number input screen).

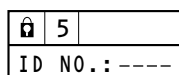

3 Press the number buttons to enter the ID number.

The lock is temporarily released so you can view the TV channel.

If you have forgotten the ID number:

Perform step 1 of "To set this function".

After confirming the ID number, press the TV/VIDEO button to exit the menu.

- When you would like to cancel the CHANNEL GUARD function, you must perform the operation "To set this function" again.

■ AUTO SHUTOFF

You can set your TV to turn off if no signal are received for about 15 minutes or longer after the end of a broadcast.

ON :

This function is turned on.

OFF :

This function is turned off.

- The AUTO SHUTOFF function does not turn off the TV's main power.
- The AUTO SHUTOFF will not work for a VIDEO mode.

■ VIDEO-3 SETTING

Set the VIDEO-3 SETTING correctly according to the video signal input from the external device connected to the VIDEO-3 terminal. If this setting is incorrect, images will not be displayed.

VIDEO :

If a normal video signal (composite video signal) is input.

COMPONENT :

If a Component video signal (Y/C_B/C_R signals) is input.

- For detailed connecting methods, see "Additional preparation" on page 27.
- This Television is compatible with the Progressive Video Signal (525P signal) only when the component video signal is input.

INSTALL menu

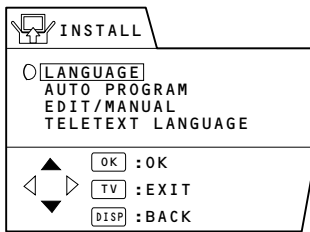

LANGUAGE

You can choose the language you want to use for the on-screen display from the language list in a menu.

- 1 Choose LANGUAGE, then press the MENU/OK button.

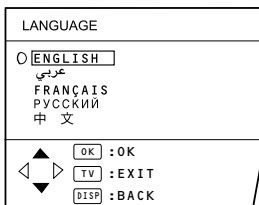

- 2 Press the ▲/▼ buttons to choose a language.
- 3 Press the MENU/OK button to complete the setting.

The menu disappears.

AUTO PROGRAM

You can automatically register the TV channels which can be received well at your residence in the TV's programme numbers by performing the following.

- 1 Choose AUTO PROGRAM, then press the MENU/OK button.
The AUTO PROGRAM function starts.
The TV channels you receive are automatically stored in the programme numbers list.

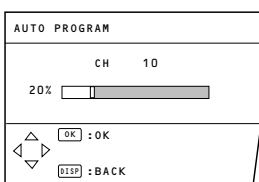

- To cancel the AUTO PROGRAM function, press the DISPLAY button.
- 2 After the TV channels have been stored in the programme number list, the EDIT menu appears.

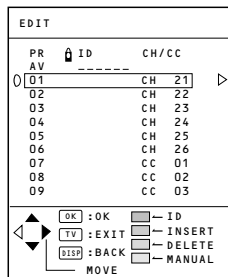

- You can proceed to edit the programme numbers list using the EDIT/MANUAL function. For details, see "EDIT/MANUAL" on page 23.
- If a TV channel you want to view is not stored in the programme numbers list, you can register it using the MANUAL function. For details, see "EDIT/MANUAL" on page 23.
- The AUTO PROGRAM function does not store a TV channel to the programme number 0 (AV).
- If you do not need to use the EDIT/MANUAL function, press the MENU/OK button to exit from the EDIT menu.

EDIT/MANUAL

The EDIT/MANUAL functions are divided into two types: editing of the current programme numbers (EDIT functions) and manual registration of a TV channel you want to view to the programme number (MANUAL function).

CAUTION

- Using the MOVE,DELETE or INSERT function rewrites the current programme numbers list. Resultingly, the programme number of some of the TV channels will change.

- When a TV channel which has been locked out using the CHANNEL GUARD function, using the MANUAL function for that TV channel cancels the CHANNEL GUARD function.
- When a TV channel has already been registered in PR 99, using the INSERT function deletes the TV channel.

- 1 Choose EDIT/MANUAL, then press the MENU/OK button.

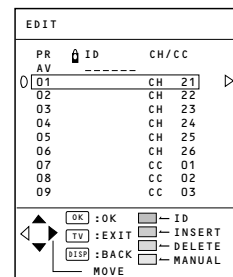

- 2 Follow the operation description of a function you want to use and operate the function.

MOVE :

This function changes a programme number of a TV channel.

ID :

This function registers a Channel name (ID) to a TV channel.

INSERT:

This function adds a new TV channel in the current programme numbers list by using the CH/CC number.

DELETE :

This function deletes a unnecessary TV Channel.

MANUAL :

This function manually registers a new TV channel in a programme number.

- 3 Press the MENU/OK button to complete the setting.

- For programme number PR 0, "AV" appears in the programme numbers list.

EDIT/MANUAL FUNCTIONS

MOVE

- 1 Press the ▲/▼ buttons to choose a TV channel.
- 2 Press the ► button to start the MOVE function.

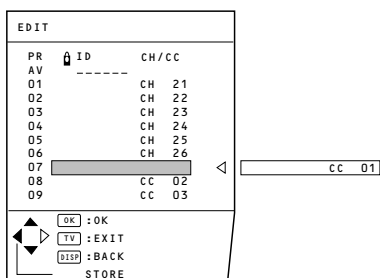

- 3 Press the ▲/▼ buttons to choose a new programme number.

To cancel the MOVE function: Press the DISPLAY button.

- 4 Press the ◀ button to change the programme number of a TV channel to a new programme number.

ID

- 1 Press the ▲/▼ buttons to choose a TV channel.
- 2 Press the red button to start the ID function.
- 3 Enter a channel name (ID). Press the ▲/▼ buttons to choose a character. press the ◀/▶ buttons to move the cursor.

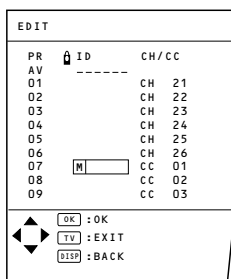

To cancel the ID function: Press the DISPLAY button.

- 4 Press the MENU/OK button to register a channel name to a TV channel.

DELETE

- 1 Press the ▲/▼ buttons to choose a TV channel.
- 2 Press the yellow button to delete the TV channel.

The TV channel is deleted from the programme numbers list.

MANUAL

- 1 Press the ▲/▼ buttons to choose a programme number to which you want to register a new TV channel.
- 2 Press the blue button to activate the MANUAL function.

At the right side following the CH/CC number, the SYSTEM (sound system) of the TV channel appears.

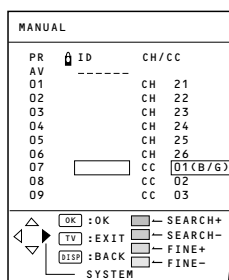

To cancel the MANUAL function: Press the DISPLAY button.

- 3 Press the ► button to choose the system (sound system) for a TV channel you want to register.

•For the sound systems in each country or region, see the table "BROADCASTING SYSTEMS" on page 11.

- 4 Press the green or red button to search for a TV channel.

Scanning stops when the TV finds a TV channel. Then the TV channel is displayed.

- 5 Press the green or red button repeatedly until the TV channel you want appears.

If the TV channel reception is poor:

Press the blue or yellow button to finetune the TV channel.

If you cannot hear the normal sound even when the picture of the TV channel appears normally:

The SYSTEM setting is wrong. Press the ► button and choose a SYSTEM that has normal sound.

- 6 Press the MENU/OK button and register the TV channel to a programme number.

The normal EDIT menu is resumed.

INSERT

PREPARATION

- Find the CH/CC number corresponding to the channel number of the TV channel from the on page 25.

- 1 Press the ▲/▼ buttons to choose a programme number for which you will register a new TV channel.
- 2 Press the green button to start the INSERT function.

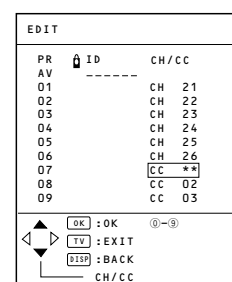

- 3 Press the ▲/▼ buttons to choose "CC" or "CH" according to the CH/CC number of the TV channel.

To cancel the INSERT function: Press the DISPLAY button.

CH/CC number

4 Press the Number buttons to enter the remaining CH/CC number.

The TV shifts to registration mode.

When the registration is completed, the picture of the TV channel appears on the screen.

- The CH/CC number is a number indicating the broadcast frequency to the TV. If the TV cannot detect the TV channel corresponding to the broadcast frequency indicated by the CH/CC number, a picture in the no-signal state appears.

When you want to use the INSERT function on page 24, find the CH/CC number corresponding to the Channel number of the TV channel from this table.

- US : The US channel numbers are the channel numbers used in the United States, Philippines, etc.
- CCIR : The CCIR channel numbers are the channel numbers used in the Middle East, Southeast Asia ,etc.
- OIRT : The OIRT channel numbers are the channel numbers used in Eastern Europe,Russia, Vietnam, etc.
- CHINA : The CHINA channel numbers are the channel numbers used in china,etc.
- AUSTRALIA: The AUSTRALIA channel numbers are the channel numbers used in Australia, etc.

CH	Channel				
	US	CCIR	OIRT	CHINA	AUSTRALIA
CH 02	US-2	E2	R1	DS-1	AU-0
CH 03	US-3	E3		DS-2	AU-1
CH 04	US-4	E4	R2	DS-3	AU-2
CH 05	US-5	E5	R6	DS-7	AU-6
CH 06	US-6	E6	R7	DS-8	AU-7
CH 07	US-7	E7	R8	DS-9	AU-8
CH 08	US-8	E8	R9		AU-9
CH 09	US-9	E9		DS-10	
CH 10	US-10	E10	R10	DS-11	AU-10
CH 11	US-11	E11	R11	DS-12	AU-11
CH 12	US-12	E12	R12	Z-8	
CH 13	US-13				
CH 14	US-14				
CH 15	US-15				
CH 16	US-16				
CH 17	US-17				
CH 18	US-18				
CH 19	US-19				
CH 20	US-20				
CH 21	US-21	E21		DS-13	
CH 22	US-22	E22		DS-14	
CH 23	US-23	E23		DS-15	
CH 24	US-24	E24		DS-16	
CH 25	US-25	E25		DS-17	
CH 26	US-26	E26		DS-18	
CH 27	US-27	E27		DS-19	
CH 28	US-28	E28		DS-20	
CH 29	US-29	E29		DS-21	
CH 30	US-30	E30		DS-22	
CH 31	US-31	E31		DS-23	
CH 32	US-32	E32		DS-24	
CH 33	US-33	E33			
CH 34	US-34	E34			
CH 35	US-35	E35			
CH 36	US-36	E36			
CH 37	US-37	E37			
CH 38	US-38	E38		DS-25	
CH 39	US-39	E39		DS-26	
CH 40	US-40	E40		DS-27	
CH 41	US-41	E41		DS-28	
CH 42	US-42	E42		DS-29	
CH 43	US-43	E43		DS-30	
CH 44	US-44	E44		DS-31	
CH 45	US-45	E45		DS-32	
CH 46	US-46	E46		DS-33	
CH 47	US-47	E47		DS-34	
CH 48	US-48	E48		DS-35	
CH 49	US-49	E49		DS-36	
CH 50	US-50	E50		DS-37	
CH 51	US-51	E51		DS-38	
CH 52	US-52	E52		DS-39	
CH 53	US-53	E53		DS-40	
CH 54	US-54	E54		DS-41	
CH 55	US-55	E55		DS-42	
CH 56	US-56	E56		DS-43	
CH 57	US-57	E57		DS-44	
CH 58	US-58	E58		DS-45	
CH 59	US-59	E59		DS-46	
CH 60	US-60	E60		DS-47	
CH 61	US-61	E61		DS-48	
CH 62	US-62	E62		DS-49	
CH 63	US-63	E63		DS-50	
CH 64	US-64	E64		DS-51	
CH 65	US-65	E65		DS-52	
CH 66	US-66	E66		DS-53	
CH 67	US-67	E67		DS-54	
CH 68	US-68	E68		DS-55	
CH 69	US-69	E69		DS-56	
CH 70				DS-57	

CC	Channel				
	US	CCIR	OIRT	CHINA	AUSTRALIA
CC 01		S-1			AU-5
CC 02		S-2		Z-1	
CC 03		S-3		Z-2	
CC 04		S-4		Z-3	
CC 05		S-5		Z-4	
CC 06		S-6			AU-5A
CC 07		S-7		Z-5	
CC 08		S-8		Z-6	
CC 09		S-9		Z-7	
CC 10		S-10		DS-6	
CC 11		S-11		Z-9	
CC 12		S-12		Z-10	
CC 13		S-13		Z-11	
CC 14	A	S-14			
CC 15	B	S-15		Z-12	
CC 16	C	S-16		Z-13	
CC 17	D	S-17		Z-14	
CC 18	E	S-18		Z-15	
CC 19	F	S-19		Z-16	
CC 20	G	S-20		Z-17	
CC 21	H	S-21		Z-18	
CC 22	I	S-22		Z-19	
CC 23	J	S-23		Z-20	
CC 24	K	S-24		Z-21	
CC 25	L	S-25		Z-22	
CC 26	M	S-26		Z-23	
CC 27	N	S-27		Z-24	
CC 28	O	S-28		Z-25	
CC 29	P	S-29		Z-26	
CC 30	Q	S-30		Z-27	
CC 31	R	S-31		Z-28	
CC 32	S	S-32		Z-29	
CC 33	T	S-33		Z-30	
CC 34	U	S-34		Z-31	
CC 35	V	S-35		Z-32	
CC 36	W	S-36		Z-33	
CC 37	W+1	S-37		Z-34	
CC 38	W+2	S-38		Z-35	
CC 39	W+3	S-39		Z-36	
CC 40	W+4	S-40		Z-37	
CC 41	W+5	S-41			
CC 42	W+6				
CC 43	W+7				
CC 44	W+8				
CC 45	W+9				
CC 46	W+10				
CC 47	W+11				
CC 48	W+12				
CC 49	W+13				
CC 50	W+14				
CC 51	W+15				
CC 52	W+16				
CC 53	W+17				
CC 54	W+18				
CC 55	W+19				
CC 56	W+20				
CC 57	W+21				
CC 58	W+22				
CC 59	W+23				
CC 60	W+24				
CC 61	W+25				
CC 62	W+26				
CC 63	W+27				
CC 64	W+28				
CC 75		X			
CC 76		Y	R3	DS-4	
CC 77		Z	R4	DS-5	AU-3
CC 78		Z+1	R5		
CC 79		Z+2			AU-4
CC 95	A-5				
CC 96	A-4				
CC 97	A-3				
CC 98	A-2				
CC 99	A-1				

■ TELETEXT LANGUAGE

There are 4 types of teletext language groups. Set the teletext language group that corresponds to the language of the teletext program that you want to watch.

1 Choose TELETEXT LANGUAGE, then press the MENU/OK button.

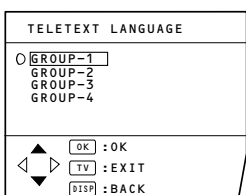

2 Press the ▲/▼ buttons to choose a group.

Group	Languages
GROUP-1	Turkish, Hungarian, English, German, French, Italian, Spanish, Portuguese, Greek, Swedish, Finnish
GROUP-2	Polish, Serbian, Croatian, Slovenian, Czech, Slovak, Rumanian, Hungarian, German, French, Italian, Swedish, Finnish
GROUP-3	Russian, Bulgarian, Lettish, Lithuanian, Estonian, Ukrainan, Serbian, Croatian, Slovenian, Czech, Slovak, English, German
GROUP-4	Arabic, Czech, Slovak, Hungarian, English, German, French, Italian, Spanish, Portuguese, Swedish, Finnish

3 Press the MENU/OK button to complete the setting.

The menu disappears.

- Languages that are not included in the teletext language group that you select, the sub-titles of the teletext program will not be displayed properly.

Additional preparation

■ Connecting the external devices

Connect the devices to the TV, paying attention to the following connection diagram.

Before connecting anything:

- Read the manuals provided with the devices. Depending on the devices, the connection method may differ from the figure. In addition, the device settings may be changed depending on the connection method to secure proper operation.
- Turn off all the devices including the TV.
- The "Specifications" on page Back cover contains the details of the VIDEO terminals. If you are connecting a device not listed in the following connection diagram, see the "Specifications" to choose the best VIDEO terminal.
- Note that connecting cables are not supplied.
- When connecting devices that are supported by AV COMPU LINK, see "Connecting AV COMPU LINK Supported Devices" on page 29.

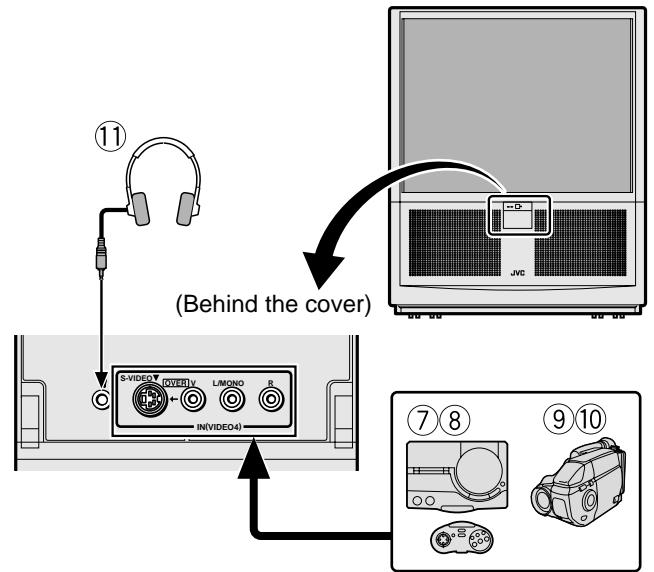

- ① VCR (composite signal)
 - ② VCR (S-VIDEO signal; Y/C)
 - ③ VCR for recording (composite signal)
 - ④ DVD player (composite signal)
 - ⑤ DVD player (S-VIDEO signal; Y/C)
 - ⑥ DVD player (component video signals; Y/C_B/C_R)
 - ⑦ TV game (composite signal)
 - ⑧ TV game (S-VIDEO signal; Y/C)
 - ⑨ Camcorder (composite signal)
 - ⑩ Camcorder (S-VIDEO signal; Y/C)
 - ⑪ Headphones
- Ⓐ AV COMPU LINK cable

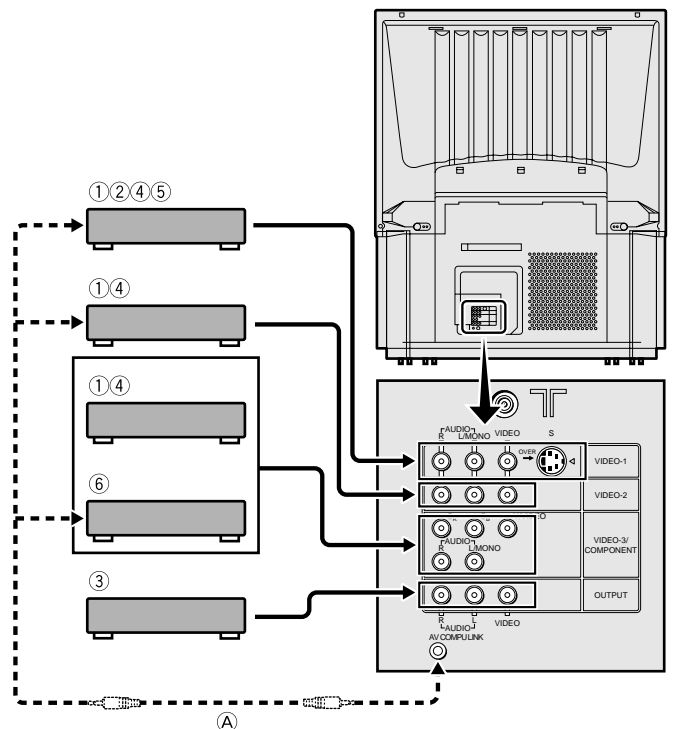

Connecting methods

- 1 Connect the TV's VIDEO jack and the device's VIDEO OUT (video output) jack with a video cable.

If connecting a device to the TV with an S-VIDEO cable:

Connect the VCR's S-VIDEO OUT (S-VIDEO output) connector and the TV's S-VIDEO connector with an S-VIDEO cable, instead of connecting with a video cable.

Note that the connection with a video cable will be ignored in case you connect a VCR to the TV with both video cable and S-VIDEO cable.

- In the VIDEO-1 terminal, the S-VIDEO connector is indicated by "S".

If connecting a DVD player to the TV with a component video cable:

Connect three jacks (Y/VIDEO, C_B and C_R) in the VIDEO-3 terminal and the DVD player's COMPONENT (component video output) jacks with a component video cables, instead of connection with a video cable.

Then set the VIDEO-3 SETTING to COMPONENT, according to "VIDEO-3 SETTING" on page 22.

- This Television is compatible with the Progressive video signal (525P signal). (When the component video signal is input.)

If you have a DVD player that outputs Progressive video signals (525P) as a component video signal, then by attaching the device to the television with a component video cable you can see the actual images that are recorded on a DVD disc as an original image source.

If connecting a device to the VIDEO-3/COMPONENT terminal with a video cable:

Connect the TV's Y/VIDEO jack and the device's VIDEO OUT (video output) jack with a video cables. Then set the VIDEO-3 SETTING to VIDEO according to "VIDEO-3 SETTING" on page 22.

- In the VIDEO-4 terminal, the VIDEO jack is indicated by "V".

- 2 Connect the TV's AUDIO jacks (L/MONO and R) and the device's AUDIO OUT (audio L/R output) jacks with an audio cable.

If the device's sound output is in mono:

Connect the device's AUDIO OUT jack and the TV's L/MONO jack with an audio cable.

Connecting devices to the OUTPUT terminal

The signals of the images and sound you are currently viewing with this TV are output through the OUTPUT terminal. By connecting a VCR to the OUTPUT terminal, you can record the currently shown image and sound to that VCR. To do this, connect the VCR and OUTPUT terminal following the steps below.

- 1 Connect the VIDEO jack in the OUTPUT terminal and the VCR's VIDEO IN (video input) jack with a video cable.
- 2 Connect the AUDIO jacks (L and R) in the OUTPUT terminal and the VCR's AUDIO IN (audio L/R input) jacks with an audio cable.

- When you turn off the TV, the signals from the OUTPUT terminal are also turned off.

- The component signals input from the VIDEO-3/COMPONENT terminal cannot be output through the OUTPUT terminal.

Connecting Headphones

Connect the headphones with a stereo mini jack (of 3.5 mm in diameter) to the Headphone jack at the TV front panel.

■ Connecting AV COMPU LINK Supported Devices

AV COMPU LINK remote control system is a system in which related devices are automatically controlled when you operate one device.

If you apply this system to the TV, you can have the TV automatically perform the required operations by operating one external device. You don't have to use the TV's remote control to turn on the TV or change the VIDEO modes.

Examples of the AV COMPU LINK remote control system operations

Simply by pressing the PLAY button on a VCR or a DVD player, you can view images from the device.

Simply by inserting a pre-recorded tape (a tape with the record safety tab removed) to a VCR, you can view the tape.

Simply by operating the AV Control Receiver, you can have the TV turned on/off (in standby mode) or the VIDEO mode changed correctly.

- The performance of the AV COMPU LINK remote control system varies depending on the connected device. See the device's instruction manual.
- When you select "TV SOUND" as the input source with the AV Control Receiver, there are cases where the TV's MUTING function automatically operates and the sound from the TV's speakers is muted.
In such cases, press the VOLUME-/+ buttons or the MUTING button on the TV's remote control to cancel the MUTING function. You can regain the sound from the TV's speakers.

Conditions to use the AV COMPU LINK remote control system

- A device equipped with an AV COMPU LINK terminal is required.
- You must connect the TV and the device with an AV COMPU LINK cable.
AV COMPU LINK cable is not supplied with this TV. If an AV COMPU LINK cable is unavailable, connect them with a cable with dia. 3.5 mm (mono) male plugs at both ends.
- You must connect the device to an appropriate VIDEO terminal and set it up correctly. Otherwise the AV COMPU LINK remote control system will not function correctly. For details, see "Setting up the AV COMPU LINK remote control system".
- The TV must be in standby mode (the POWER lamp lighting red). If the TV's Main power is off (the POWER lamp off), the AV COMPU LINK remote control system does not function.

Setting up the AV COMPU LINK remote control system

CAUTION:

- With some devices, the setup method differs from the ones explained here.
Be sure to read the device's instruction manual thoroughly before setting it up.

- 1 Connect the device to the TV's VIDEO-1 or VIDEO-2 terminal.

If you want to connect a DVD player to the TV with a component video cable :

Connect the DVD player to the TV's VIDEO-3 terminal.

- For detailed connecting instructions, see "Connecting the external devices" on page 27.
- 2 Connect the TV's AV COMPU LINK terminal and the device's AV COMPU LINK terminal with an AV COMPU LINK cable.
 - 3 Change the device's setting according to the VIDEO terminal it is connected to.

If a VCR is connected to the VIDEO-1 terminal :

Set the VCR's remote control code to A code.

If a DVD player is connected to the VIDEO-1 terminal:

Set the DVD player's AV COMPULINK MODE to DVD2.

If a VCR is connected to the VIDEO-2 terminal:

Set the VCR's remote control code to B code.

If a DVD player is connected to the VIDEO-2 terminal:

Set the DVD player's AV COMPULINK MODE to DVD3.

If a DVD player is connected to the VIDEO-3 terminal with a component video cable:

Set the DVD player's AV COMPULINK MODE to DVD1.

- For instructions on how to change the device's setting, refer to the device's instruction manual.
- If the device you are connecting has neither the remote control code nor the AV COMPULINK MODE, then connect it to the TV's VIDEO-1 terminal.

Troubleshooting

If a problem arises while you are using the TV, please read this "Troubleshooting" well before you request having the TV repaired. You may be able to fix it easily by yourself. For example, if the AC plug is disconnected from the AC outlet, or the TV aerial has problems, you may think there is a problem with the TV itself.

Important:

- This Troubleshooting guide only covers problems whose cause are not easy to determine. If a question arise when you are operating a function, read the page(s) corresponding to the operation of the function well, not this Troubleshooting guide.
- After you have followed the Troubleshooting description or the operating description of the functions concerned without any success, remove the AC plug from the AC outlet and request a repair of your TV. Do not attempt to repair the TV by yourself or remove the rearcover of the TV.

■ If you cannot turn on the TV

- Is the AC plug connected to the AC outlet?
- Is the POWER lamp lit? If not, press the Main power button.

■ No picture/No sound

- Are your SOUND SYSTEM settings for the TV channels correct?
Follow the description "SOUND SYSTEM Button" on page 11 to try to solve the trouble.

■ Poor picture

- If red, green, and blue shadows appear around the contours of the image on the screen it is necessary to adjust CRT colour convergence. For details, refer to "Adjusting CRT colour convergence" on Page 6.
- If noise totally obscures the picture (snow), the aerial or aerial cable may have trouble. Check the following to try to solve the trouble :

Has the TV and aerial been connected properly?
Has the aerial cable been damaged?
Is the aerial pointed to the right direction?
Is the aerial itself faulty?

- If the TV or aerial receives interference from the other devices, stripes or noise may appear in the picture. Move such device as an amplifier, personal computer, or a hair drier that can cause interference away from your TV, or try changing its location. If the aerial suffers interference from a radio tower or high-voltage wire, please contact your local dealer.
- If the TV receives interferences from signal reflecting from mountains or building, double-pictures(ghosting) will occur.
Try to change the aerial's direction or replace the antenna with the one with better directionality.

- Are your COLOUR SYSTEM settings for the TV channels correct? Follow the description "COLOUR SYSTEM button" on page 11 to try to solve the trouble.
- Has COLOUR or BRIGHT been controlled properly? Follow the description "Adjusting the picture" on page 17 to try to adjust them properly.
- Videotaping teletext is not recommended because it may not record correctly.
- When a white and bright still image (such as a white dress) is displayed on the screen, the white part may look as if it were coloured. It is a phenomenon unavoidable due to the nature of the picture tube itself, and not due to a TV failure.
When the picture disappears from the screen, the unnatural colours will also disappear.
- When viewing images from commercially available video software products, or videos from videotapes which have been recored improperly, the top of the image may be distorted. This is due to the condition of the video signal, and not because of malfunction.

■ Poor sound

- Have you adjusted BASS or TREBLE properly? If not, follow the description "Adjusting the Sound" on page 20 to try to adjust them properly.
- When the TV channel reception is poor, it can be hard to hear the stereo or bilingual sound. In this case, follow the description "STEREO / I • II" on page 20 to hear the sound more easily by changing it to a mono sound.

■ Operation disabled

- Have the batteries of the remote control become exhausted?
Follow the description "Putting the Batteries into the Remote Control" on page 4 and replace them with new batteries to try solve the problem.
- Have you attempted to use the remote control at the sides or rear of the TV or at a location more than seven meters apart from the TV location?
Operate the remote control in the front of your TV or a location less than seven meters from your TV to try to solve the problem.
- When you are viewing a teletext programme, you cannot operate the menus.
Press the TV/VIDEO button to return the teletext programme to the ordinary TV programme to try operating the menus.
- Is the CHILD LOCK function set to ON?
If the CHILD LOCK function is set to ON, you cannot operate the TV with the front control buttons of the TV. Follow the description "CHILD LOCK" on page 21 to try to set the CHILD LOCK function to OFF.
- If the TV operation becomes disabled suddenly, press the Main power button on the TV and turn off the main power.
Try to press the Main power button again to turn on the main power. If the TV returns to a normal state, it is not a failure.
- The following functions do not operate when receiving Progressive Video Signal (525P signal);
Remote control function:
ZOOM, PIP, MULTI, FREEZE and STROBE
BUTTON
MENU function:
SHARP, TINT, DIGITAL VNR, Digipure and ZOOM

■ Other concerns

- When the SLEEP TIMER function or AUTO SHUTOFF function operates, the TV is automatically turned off.
If the TV is turned off suddenly, try to press the POWER button to turn on the TV once again. At this time, if the TV resumes a normal state, there is no problem.
- If you do not want sound emitted from the TV's speakers when using headphones, change the TV SPEAKER setting in the HEADPHONE menu to OFF. For details, see "HEADPHONE" on page 20.
- If you bring a magnetised device such as a speaker near to your TV, a picture may be warped or unnatural colours appear at the corners of the screen.
In this case, keep the device apart from your TV. If the speaker causes such phenomena, use the magnetic-shielded speaker instead.
- It takes a short period of time from the time an operation such as changing channels is performed until an image is displayed. This is not a malfunction.
This is the time required for the image to stabilize before it can be displayed.
- The TV may emit a crackling sound due to a sudden change in temperature. It does not matter if a picture or sound does not show any abnormality. If you hear crackling sounds frequently while you are viewing the TV, other causes may be assumed.
For precautionary purposes, request your service technician to inspect it.
- If you jolt this TV, the picture may shake.
This is not a malfunction.

Specifications

Broadcasting systems	B, G, I, D, K, K1, M
Colour systems	PAL, SECAM, NTSC3.58/4.43MHz
Channels and frequencies	VHF low channel (VL) =46.25 to 168.25 MHz VHF high channel (VH) =175.25 to 463.25 MHz UHF channel(U) =471.25 to 863.25 MHz <ul style="list-style-type: none"> ■ Receives cable channels in mid band (X to Z+2, S1 to S10), super band (S11 to S20) and hyper band (S21 to S41).
Sound-multiplex systems	A2 (B/G), NICAM (B/G, I, D/K) system
Teletext systems	FLOF(Fastext), WST(World Standard Text)
Lauguages displayed by teletext	Please see the table in the description "TELETEXT LANGUAGE" on page 26
Power requirements	AC 110 to 240V, 50/60Hz
Power consumption	Maximum 287W Average 208W
Screen size	1346 mm (measured diagonally)
Audio output	Rated Power output: 20W + 20W
Speakers	16 cm round X 2
VIDEO-1 terminal	RCA connector X 3, S-VIDEO connector X 1 <ul style="list-style-type: none"> • Video input, S-VIDEO (Y/C) input and Audio L/R inputs are available.
VIDEO-2 terminal	RCA connector X 3 <ul style="list-style-type: none"> • Video input and Audio L/R inputs are available.
VIDEO-3/COMPONENT terminal	RCA connector X 5 <ul style="list-style-type: none"> • Video input/Component video (Y/C_b/C_r) input and Audio L/R inputs are available. • Progressive video signal (525P signal) input is available.
VIDEO-4 terminal	RCA connector X 3, S-VIDEO connector X 1 <ul style="list-style-type: none"> • Video input, S-VIDEO (Y/C) input and Audio L/R inputs are available.
OUTPUT terminal	RCA connector X 3 <ul style="list-style-type: none"> • Video output and Audio L/R outputs are available.
Headphone jack	Stereo mini-jack (3.5 mm in diameter)
Dimensions(W X H X D)	1200 mm X 1454 mm X 619 mm
Weight	85 kg
Accessories	Remote control unit X 1 (RM-C214) AA/R6 dry cell battery X 2

Design and specifications subject to change without notice.

Pictures displayed on the screen using this TV's ZOOM functions should not be shown for any commercial or demonstration purpose in public places (cafes,hotels, etc.) without the consent of the owners of copyright of the original picture sources, as this constitutes an infringement of copyright.

JVC
VICTOR COMPANY OF JAPAN, LIMITED